

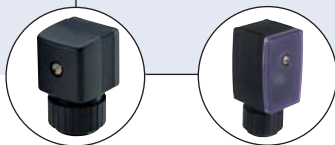

Type 6027 Compact can be combined with...



**Type 2508**

Cable plug

**Type 2511**

Cable plug

Valve 6027 is a direct-acting plunger valve. The stopper and plunger guiding tube are welded together to enhance pressure resistance and leak-tightness. Various seal material combinations are available depending on the application. The coils are moulded with chemically resistant epoxy. 'Kick and Drop' electronics are available for overexcitation (plug 2511) for the reduction of electrical power consumption during operation. An optional sliding ring bearing increases the service life with dry gases. Special seal technology is used for high-pressure applications. In combination with a plug in accordance with DIN EN 17301-803 Form A, the valves satisfy protection class IP65. Stainless steel valves satisfy NEMA 4X.

**Circuit function A**

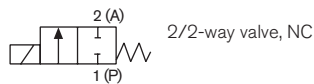

**Circuit function B**

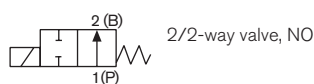

## Direct-acting 2/2-way plunger valve

- Direct-acting, powerful valve with diameter of up to DN 12
- Vibration-proof, bolted coil system
- Increased leak-tightness with welded plunger guiding tube
- Explosion proof versions

Technical data			
<b>Port connection</b>	G 1/4, G 3/8, G 1/2 (RC on request)		
<b>Orifice</b>	DN 1.0 - 12.0		
<b>Body material</b>	Brass or stainless steel 1.4404 (316L)		
<b>Coil material</b>	Epoxy		
<b>Coil insulation class</b>	Epoxy class H		
<b>Seal material</b>	FKM, PTFE / FKM and PTFE / PEEK for high temperatures (EPDM on request)		
<b>Medium</b>	Vacuum, neutral gases and liquids (e.g. compressed air, town gas, natural gas, water, hydraulic oil, petrol) and slightly aggressive medium Hot liquids and steam		
<b>Seal material combination and medium temperature</b>			
<b>Seat seal/external seal</b>			
Circuit function Normally Closed (NC)	Circuit function Normally Open (NO)		
FKM/FKM	-10 to +140°C	FKM/FKM	-10 to +100°C
PEEK/FKM	-10 to +80°C	PEEK/FKM	-10 to +80°C
PTFE/PEEK	-40 to +140°C	PTFE/PEEK	-40 to +100°C
NBR/NBR	-10 to +80°C		
<b>Voltage tolerance</b>	±10%		
<b>Duty cycle / single valve</b>	100% continuous rating		
<b>Electrical connection</b>	acc. to DIN EN 175301-803 Form A for cable plug Type 2508 (see accessories ordering chart)		
<b>Protection class</b>	IP65 with Cable Plug		
<b>Installation</b>	As required, preferably with actuator upright		

Power ratings				
Orifice [mm]	Power ratings			
	Inrush AC [VA]	Hold AC (hot coil) [VA] [W]		DC (hot/cold coil) [W]
1.0 -12.0	105	37	16	16 / 21

Response times				
Orifice [mm]	Response times AC		Response times DC	
	Opening [ms]	Closing [ms]	Opening [ms]	Closing [ms]
1.0 -12.0	10-30	20-30	20-80	20-30

**Response times [ms]:**  
Measured at valve outlet at 6 bar and +20 °C  
Opening: pressure build-up 0 to 90%, closing: pressure relief 100 to 10%

## Ordering chart for valves, brass

## G internal thread

Brass body material, medium pressure up to 30 bar, G internal thread																
Circuit function	Port connection	Orifice	Kv-value water (m <sup>3</sup> /h)	Max. medium pressure (bar)						Seal material		Item No.				
				water		oil		air		FKM/FKM Standard	PTFE/PEEK possible option	24V DC	24V 50Hz	230V 50Hz		
				DC	AC	DC	AC	DC	AC							
NC 	G1/4	3.0	0.28	0-30	0-25	0-30	0-25	0-30	0-25	0-25	x	A	178 295	178 296	178 297	
		4.0	0.54	0-12	0-16	0-12	0-16	0-12	0-16	0-16	x	A	178 299	178 300	178 301	
		5.0	0.73	0-6	0-10	0-6	0-10	0-6	0-10	0-6	0-10	x	A	178 303	178 304	178 305
		6.0	0.95	0-3	0-6	0-3	0-6	0-3	0-6	0-6	0-6	x	A	178 307	178 308	178 309
	G3/8	3.0	0.28	0-30	0-25	0-30	0-25	0-30	0-25	0-25	x	A	178 311	178 312	178 313	
		4.0	0.54	0-12	0-16	0-12	0-16	0-12	0-16	0-16	x	A	178 315	178 316	178 317	
		5.0	0.73	0-6	0-10	0-6	0-10	0-6	0-10	0-6	0-10	x	A	178 319	178 320	178 321
		6.0	0.95	0-3	0-6	0-3	0-6	0-3	0-6	0-6	0-6	x	A	178 323	178 324	178 325
	G1/2	6.0	0.95	0-3	0-6	0-3	0-6	0-3	0-6	0-6	x	A	178 331	178 332	178 333	
		8.0	1.6	0-1	0-3	0-1	0-3	0-1	0-3	0-3	x	A	178 335	178 336	178 337	
		10.0	1.8	0-0.4	0-2	0-0.4	0-2	0-0.4	0-2	0-2	x	A	178 339	178 340	178 341	
		8.0	1.6	0-1	0-3	0-1	0-3	0-1	0-3	0-3	x	A	178 335	178 336	178 337	
	NO	G1/4	3.0	0.28	0-16	0-16	0-16	0-16	0-16	0-16	0-16	x	A	211 914	228 487	228 488
			4.0	0.54	0-10	0-10	0-10	0-10	0-10	0-10	0-10	x	A	208 623	228 489	228 490
6.0			0.95	0-6	0-6	0-6	0-6	0-6	0-6	0-6	x	A	211 915	A	227 530	
G1/2		8.0	1.6	0-3	0-3	0-3	0-3	0-3	0-3	0-3	x	A	211 916	228 503	228 504	
		10.0	1.8	0-2	0-2	0-2	0-2	0-2	0-2	0-2	x	A	210 436	219 530	210 438	

## NPT internal thread

Brass body material, medium pressure up to 30 bar, NPT internal thread																
Circuit function	Port connection	Orifice	Kv-value water (m <sup>3</sup> /h)	Max. medium pressure (bar)						Seal material		Item No.				
				water		oil		air		FKM/FKM Standard	PTFE/PEEK possible option	24V DC	24V 50Hz	230V 50Hz		
				DC	AC	DC	AC	DC	AC							
NC 	NPT1/4	3.0	0.28	0-30	0-25	0-30	0-25	0-30	0-25	0-25	x	A	463 120	A	A	
		4.0	0.54	0-12	0-16	0-12	0-16	0-12	0-16	0-16	x	A	463 122	A	A	
		5.0	0.73	0-6	0-10	0-6	0-10	0-6	0-10	0-6	0-10	x	A	463 124	A	A
		6.0	0.95	0-3	0-6	0-3	0-6	0-3	0-6	0-6	0-6	x	A	463 126	A	A
	NPT3/8	3.0	0.28	0-30	0-25	0-30	0-25	0-30	0-25	0-25	x	A	A	A	A	
		4.0	0.54	0-12	0-16	0-12	0-16	0-12	0-16	0-16	x	A	463 130	A	A	
		5.0	0.73	0-6	0-10	0-6	0-10	0-6	0-10	0-6	0-10	x	A	463 132	A	A
		6.0	0.95	0-3	0-6	0-3	0-6	0-3	0-6	0-6	0-6	x	A	463 134	A	A
	NPT1/2	8.0	1.6	0-1	0-3	0-1	0-3	0-1	0-3	0-3	0-3	x	A	463 136	A	A
		6.0	0.95	0-3	0-6	0-3	0-6	0-3	0-6	0-6	0-6	x	A	463 138	A	A
		8.0	1.6	0-1	0-3	0-1	0-3	0-1	0-3	0-3	0-3	x	A	463 140	A	A
		10.0	1.8	0-0.4	0-2	0-0.4	0-2	0-0.4	0-2	0-2	0-2	x	A	463 142	A	A
	NO	NPT1/4	3.0	0.28	0-16	0-16	0-16	0-16	0-16	0-16	0-16	x	A	A	A	A
			4.0	0.54	0-10	0-10	0-10	0-10	0-10	0-10	0-10	x	A	A	A	A
6.0			0.95	0-6	0-6	0-6	0-6	0-6	0-6	0-6	x	A	A	A	A	
NPT1/2		8.0	1.6	0-3	0-3	0-3	0-3	0-3	0-3	0-3	x	A	A	A	A	
		10.0	1.8	0-2	0-2	0-2	0-2	0-2	0-2	0-2	x	A	A	A	A	

## Ordering chart for valves, stainless steel

## G internal thread

Stainless steel body material, medium pressure up to 30 bar, G internal thread															
Circuit function	Port connection	Orifice	Kv-value water (m <sup>3</sup> /h)	Max. medium pressure (bar)						Seal material		Item No.			
				water		oil		air		FKM/FKM Standard	PTFE/PEEK possible option	24V DC	24V 50Hz	230V 50Hz	
				DC	AC	DC	AC	DC	AC						
 42 mm NC	G1/4	3.0	0.28	0-30	0-25	0-30	0-25	0-30	0-25	x	A	178 239	178 240	178 241	
		4.0	0.54	0-12	0-16	0-12	0-16	0-12	0-16	x	A	178 243	178 244	178 245	
		5.0	0.73	0-6	0-10	0-6	0-10	0-6	0-10	x	A	178 247	178 248	178 249	
		6.0	0.95	0-3	0-6	0-3	0-6	0-3	0-6	x	A	178 251	178252	178 253	
	G3/8	3.0	0.28	0-30	0-25	0-30	0-25	0-30	0-25	x	A	178 255	178 256	178 257	
		4.0	0.54	0-12	0-16	0-12	0-16	0-12	0-16	x	A	178 259	178 260	178 261	
		5.0	0.73	0-6	0-10	0-6	0-10	0-6	0-10	x	A	178 263	178 264	178 265	
		6.0	0.95	0-3	0-6	0-3	0-6	0-3	0-6	x	A	178 267	178 268	178 269	
	G1/2	6.0	0.95	0-3	0-6	0-3	0-6	0-3	0-6	x	A	178 275	178 276	178 277	
		8.0	1.6	0-1	0-3	0-1	0-3	0-1	0-3	x	A	178 279	178 280	178 281	
		10.0	1.8	0-0.4	0-2	0-0.4	0-2	0-0.4	0-2	x	A	178 283	178 284	178 285	
		12.0	2	0-0.2	0-1.2	0-0.2	0-1.2	0-0.2	0-1.2	x	A	178 287	178 288	178 289	
	NO	G1/4	3.0	0.28	0-16	0-16	0-16	0-16	0-16	0-16	x	A	230 243	230 244	230 245
			4.0	0.54	0-10	0-10	0-10	0-10	0-10	0-10	x	A	230 246	230 247	230 248
G3/8		6.0	0.95	0-6	0-6	0-6	0-6	0-6	0-6	x	A	230 255	230 256	230 257	
G1/2		8.0	1.6	0-3	0-3	0-3	0-3	0-3	0-3	x	A	230 261	230 262	230 263	
		10.0	1.8	0-2	0-2	0-2	0-2	0-2	0-2	x	A	225 248	230 264	230 265	

## NPT internal thread

Stainless steel body material, medium pressure up to 30 bar, NPT internal thread															
Circuit function	Port connection	Orifice	Kv-value water (m <sup>3</sup> /h)	Max. medium pressure (bar)						Seal material		Item No.			
				water		oil		air		FKM/FKM Standard	PTFE/PEEK possible option	24V DC	24V 50Hz	230V 50Hz	
				DC	AC	DC	AC	DC	AC						
 42 mm NC	NPT1/4	3.0	0.28	0-30	0-25	0-30	0-25	0-30	0-25	x	A	A	A	A	
		4.0	0.54	0-12	0-16	0-12	0-16	0-12	0-16	x	A	A	A	A	
		5.0	0.73	0-6	0-10	0-6	0-10	0-6	0-10	x	A	A	A	A	
		6.0	0.95	0-3	0-6	0-3	0-6	0-3	0-6	x	A	A	A	A	
	NPT3/8	3.0	0.28	0-30	0-25	0-30	0-25	0-30	0-25	x	A	A	A	A	
		4.0	0.54	0-12	0-16	0-12	0-16	0-12	0-16	x	A	A	A	A	
		5.0	0.73	0-6	0-10	0-6	0-10	0-6	0-10	x	A	A	A	A	
		6.0	0.95	0-3	0-6	0-3	0-6	0-3	0-6	x	A	A	A	A	
	NPT1/2	6.0	0.95	0-3	0-6	0-3	0-6	0-3	0-6	x	A	A	A	A	
		8.0	1.6	0-1	0-3	0-1	0-3	0-1	0-3	x	A	A	A	A	
		10.0	1.8	0-0.4	0-2	0-0.4	0-2	0-0.4	0-2	x	A	A	A	A	
		12.0	2	0-0.2	0-1.2	0-0.2	0-1.2	0-0.2	0-1.2	x	A	A	A	A	
	NO	NPT1/4	3.0	0.28	0-16	0-16	0-16	0-16	0-16	0-16	x	A	A	A	A
			4.0	0.54	0-10	0-10	0-10	0-10	0-10	0-10	x	A	A	A	A
6.0		0.95	0-6	0-6	0-6	0-6	0-6	0-6	x	A	A	A	A		
NPT1/2		8.0	1.6	0-3	0-3	0-3	0-3	0-3	0-3	x	A	A	A	A	
		10.0	1.8	0-2	0-2	0-2	0-2	0-2	0-2	x	A	A	A	A	

Ordering chart for valves

**Approved models for gas applications** DIN EN 161, automatic shut-off valves for gas burners up to 5 bar, valve class A

Circuit function	Port connection	Orifice	Kv-value water (m <sup>3</sup> /h)	Max. medium pressure		Body material	Seal material NBR Standard	Item No.	
				Gas				24V DC	230V 50Hz
				DC	AC				
NC	G1/4	4.0	0.54	0-5	0-5	Br	x	A	A
	G1/4	5.0	0.73	0-5	0-5	Br	x	A	A
	G1/4	6.0	0.95	0-3	0-5	Br	x	271 196	271 427
	G3/8	8.0	1.6	0-1	0-3	Br	x	271 197	271 428
	G3/8	10.0	1.8	0-0.4	0-2	Br	x	271 198	271 429
	G1/2	12.0	2	0-0.2	0-1.2	St. st.	x	271 199	271 430

**Approved models for gas applications** DIN 3394-1 actuators for backing up and cleaning as well as regulating pressures of 4 to 16 bar, valve class B, valve group 2

Circuit function	Port connection	Orifice	Kv-value water (m <sup>3</sup> /h)	Max. medium pressure		Body material	Seal material NBR Standard	Item No.	
				Gas				24V DC	230V 50Hz
				DC	AC				
3NC	G1/4	3.0	0.28	0-30	0-25	Br	x	258 288	A
	G1/4	4.0	0.54	0-12	0-16	Br	x	253 500	A
	G1/4	5.0	0.73	0-6	0-10	Br	x	A	A
	G1/4	6.0	0.95	0-3	0-5	Br	x	A	A
	G3/8	8.0	1.6	0-1	0-3	Br	x	A	A
	G3/8	10.0	1.8	0-0.4	0-2	Br	x	A	260 041
	G1/2	12.0	2	0-0.2	0-1.2	St. st.	x	258 289	A

Version up to 16 bar  
Circuit function A (NC)

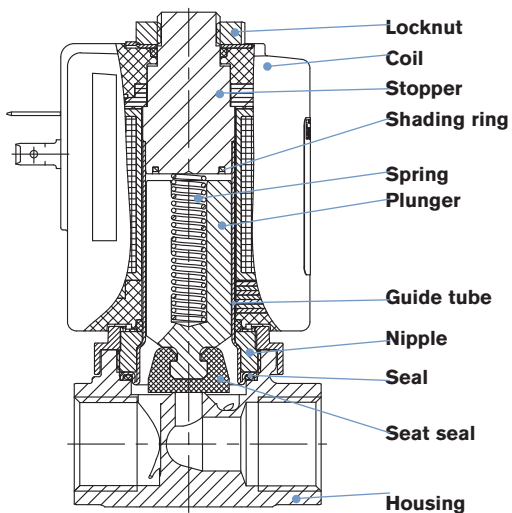

- Locknut: DIN 176 thick-film passivated or stainless steel
- Coil: Epoxy
- Stopper: Stainless steel 1.4113
- Shading ring: Copper (brass body), silver (stainless steel body)
- Spring: Stainless steel 1.4310
- Plunger: Stainless steel 1.4113
- Guide tube: Stainless steel 1.4303
- Nipple: Brass, stainless steel 1.4305
- Seal: NBR
- Seat seal: NBR
- Housing: Brass, stainless steel 1.4404 /316L

## Ordering chart for valves

Order code MX 30 high pressure version with pendulum seal														
Brass and stainless steel body material, medium pressure up to 135 bar, G internal thread cable plug included in delivery														
Circuit function	Port connection	Orifice	Kv-value water (m <sup>3</sup> /h)	max. medium pressure (bar)						Seal material		Item No.		
				water		oil		Air		PTFE/FKM Standard		24V DC	24V 50Hz	230V 50Hz
				DC	AC	DC	AC	DC	AC					
<b>Brass body</b>														
NC	G1/4	2.0		0-80	0-75	0-80	0-75	0-80	0-75	x		184 667	A	184 668
<b>Stainless steel body</b>														
NC	G1/4	1.5		0-135	0-135	0-135	0-135	0-135	0-135	x		215 024	215 028	203 855
		2.0		0-100	0-75	0-100	0-75	0-100	0-75	x		271 439	205 407	271 440

Order code MX 31 high pressure version with ball seal														
Stainless steel body material, medium pressure up to 250 bar, G internal thread cable plug included in delivery														
Circuit function	Port connection	Orifice	Kv-value water (m <sup>3</sup> /h)	max. medium pressure (bar)						Seal material		Item No.		
				Viscosity 1mm <sup>2</sup> /s		Viscosity 21mm <sup>2</sup> /s		Air		PEEK/FKM Standard		24V DC	24V 50-60Hz	230V 50-60 Hz
				DC	AC	DC	AC	DC	AC					
<b>Stainless steel body</b>														
NC	G1/4	1.0		0-250	0-250	0-250	0-250	0-250	0-250	x		265 507	(-)	267 229
						0-200	0-200			x		(-)	267 226	(-)
	1.5	0-150	0-150	0-80	0-80	0-150	0-150	x		267 217	(-)	267 237		
								0-70	0-70	x		(-)	267 234	(-)
NO	G1/4	1.0		0-200	0-200	0-150	0-150	0-250	0-250	x		269 823	A	267 239
						0-80	0-80			0-130	0-130	x		269 824

Materials

Version up to 30 bar  
Circuit function A

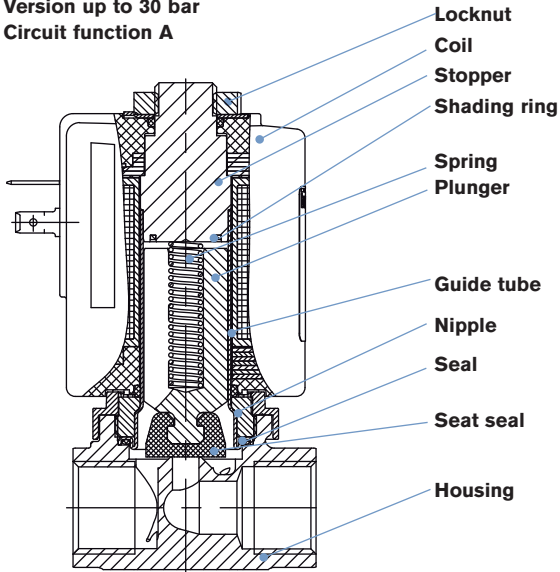

- Locknut DIN 176 thick-film passivated or stainless steel
- Coil Epoxy
- Stopper Stainless steel 1.4113
- Shading ring Copper (brass body), silver (stainless steel body)
- Spring Stainless steel 1.4310
- Plunger Stainless steel 1.4113
- Guide tube Stainless steel 1.4303
- Nipple Brass, stainless steel 1.4305
- Seal FKM, PEEK (EPDM on request)
- Seat seal FKM, PTFE (EPDM on request)
- Housing Brass, stainless steel 1.4404 /316L

Version up to 135 bar  
Circuit function A

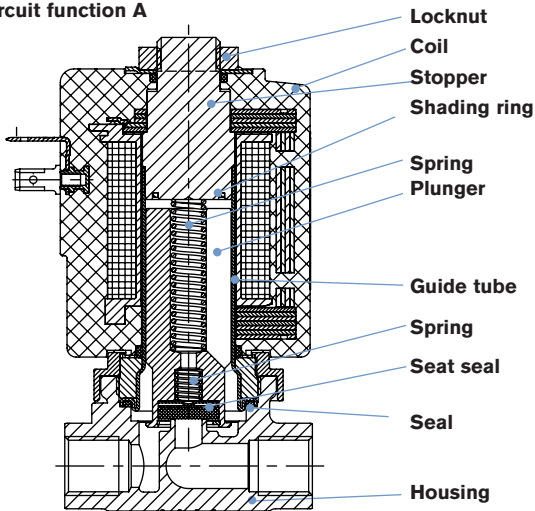

- Locknut DIN 176 thick-film passivated or stainless steel
- Coil Epoxy
- Stopper Stainless steel 1.4113
- Shading ring Silver (stainless steel body)
- Spring Stainless steel 1.4310
- Plunger Stainless steel 1.4113
- Guide tube Stainless steel 1.4303
- Spring 1.4310
- Seat seal PTFE pendulum seal
- Seal FKM
- Housing Brass, stainless steel 1.4404 /316L

• High pressure version from 135 bar  
Circuit function A

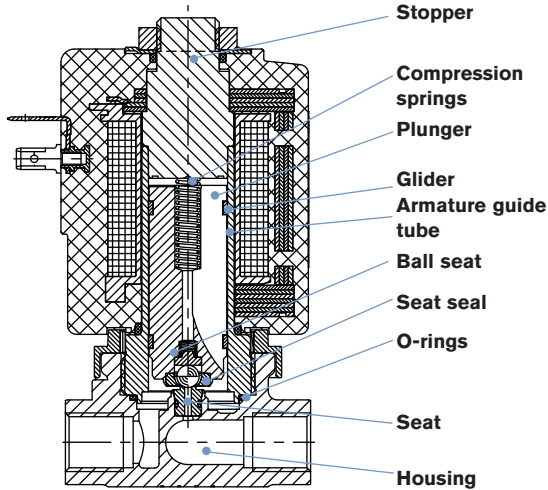

- Stopper 1.4523
- Compression springs 1.4310
- Plunger Stainless steel 1.4113
- Glider PTFE
- Armature guide tube 1.4571
- Ball seat 1.4305
- Seat seal Ceramic ball
- O-rings FKM
- Seat PEEK
- Housing Stainless steel 1.4404 (316L) only in 1/4" G and NPT

Dimensions [mm]

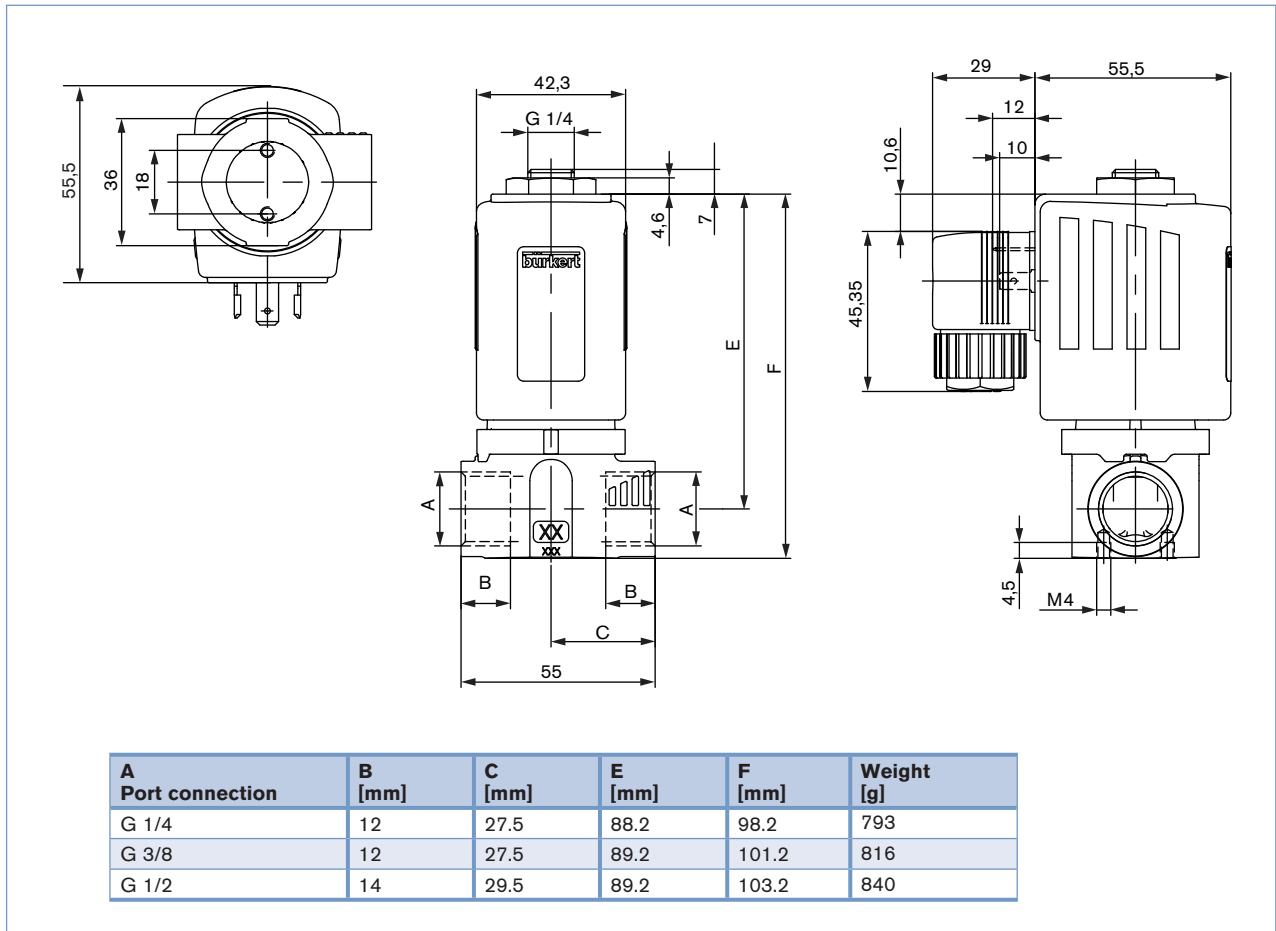

Ordering chart for accessories

Cable plug Type 2508 according to DIN EN 175301-803 Form A

	Circuitry	Voltage/ Frequency	Item No.
	without (Standard)	0 - 250 V AC/DC	008 376
	with LED	12 - 24 V AC/DC	008 360
	with LED and varistor	12 - 24 V AC/DC	008 367
	with rectifier, LED and varistor	12 - 24 V AC/DC	008 363
	with LED	200 - 240 V	008 362
	with LED and varistor	200 - 240 V	008 369
	further versions see datasheet Type 2508		

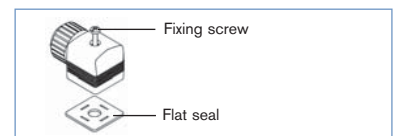

The delivery of a cable plug includes the flat seal and the fixing screw. For other cable plug versions according to DIN EN 175301-803 (previously DIN 43650) Form A, see separate datasheet for Type 2508. When you click on the orange box "More info." below, you will come to our website for the resp. product where you can download the datasheet.



To find your nearest Bürkert facility, click on the orange box



[www.burkert.com](http://www.burkert.com)

In case of special application conditions, please consult for advice.

Subject to alterations

1502/14\_EU-en\_00895015